

1

tabula rasa

ball: SV Birdie Z 25, DM 084,
Reisinger BO, Reisinger CB (Blå),
Reisinger Erbach

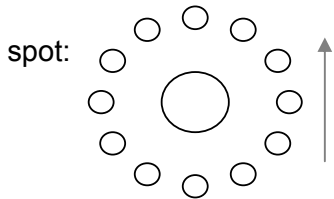
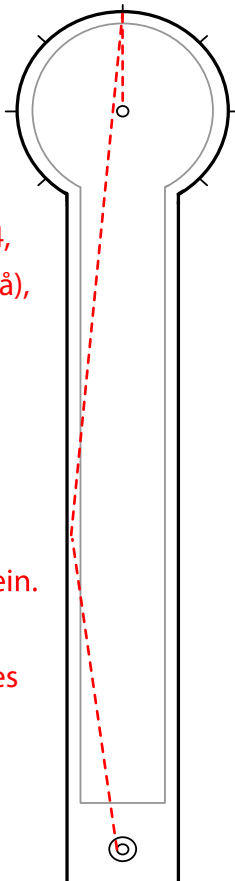

note: Vanttreff ved «gul» stein.
Ballen skal gå ca 1-5 cm
venstre om koppen. Må spilles
avveid for å gå på nakke.



18

shoot-in

ball: Vanlig innslagsball

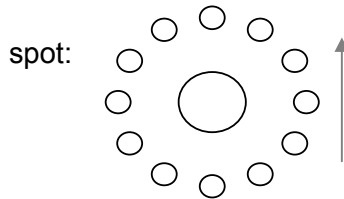

note: Spill rett frem.

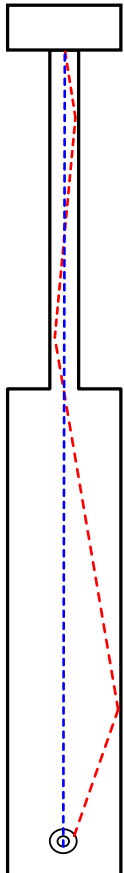

17

open tunnel

ball: DM 083, DM 085,
DM 087 (død), DM Amigo,
DM Bel Ami, DM 084w (varm)

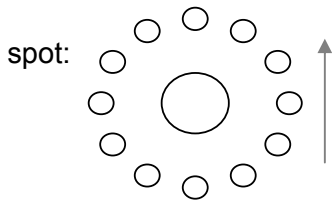

note: Legg ballen litt høyre
(ca 1 cm) og spill rett frem eller
litt høyre. Ballen skal gå
høyre om koppen på nakke.

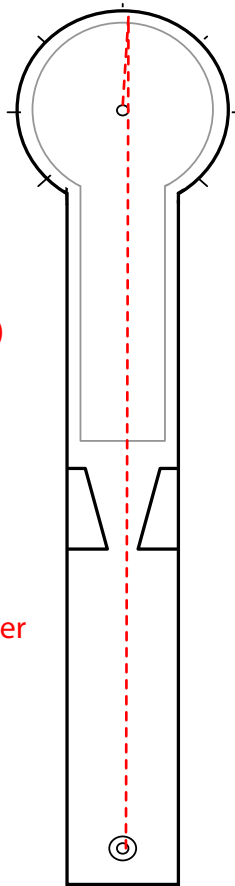

2

Stonehenge

ball: BoF Ingrid Netzband,
BoF Sandra Nordin, BoF Denis Prip,
BoF Christian Pannek, DM 085

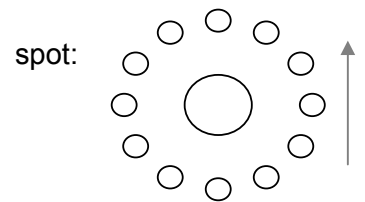

note: Spill i venstre vant ved
«hvit» stein. Ballen skal å direkte
eller høyre omkopp og på
nakke.

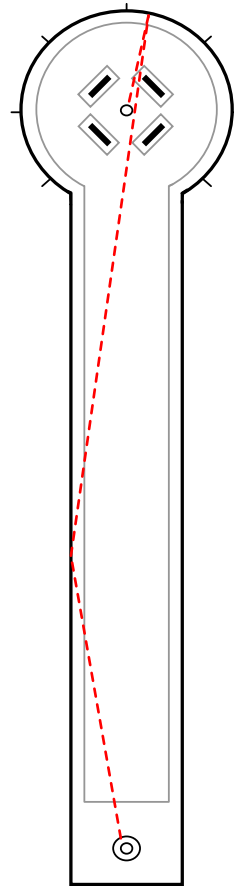

15

terrace

ball: BoF Karin Wiklund,
BoF Sweden Boys, 3D 443,
BoF «Bomml», 3D Balla-Balla 2

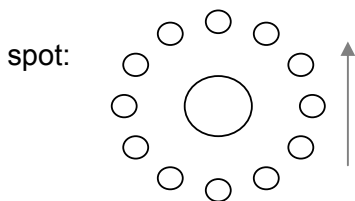

note: Legg ballen ca 1 cm
høyre og spill rett frem. Ballen
skal gå direkt eller høyre om
koppen på nakke.

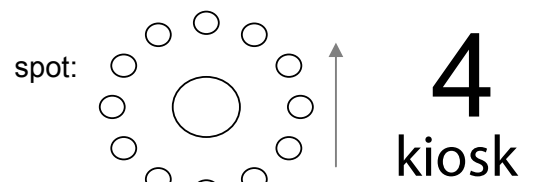
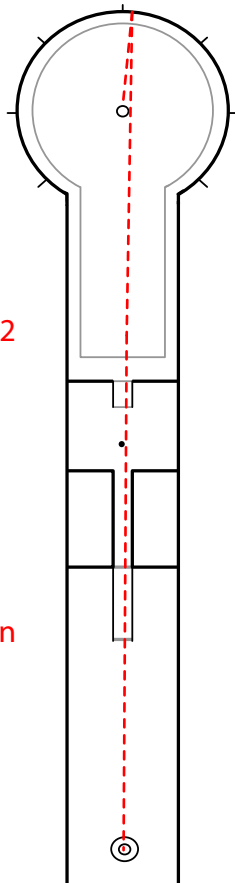

4

kiosk

ball: Mg Cl 4, Mg Cl 5

note: Legg ballen i midten og
spill litt høyre. Ballen skal høyre
om koppen og på nakke, eller
direkt.

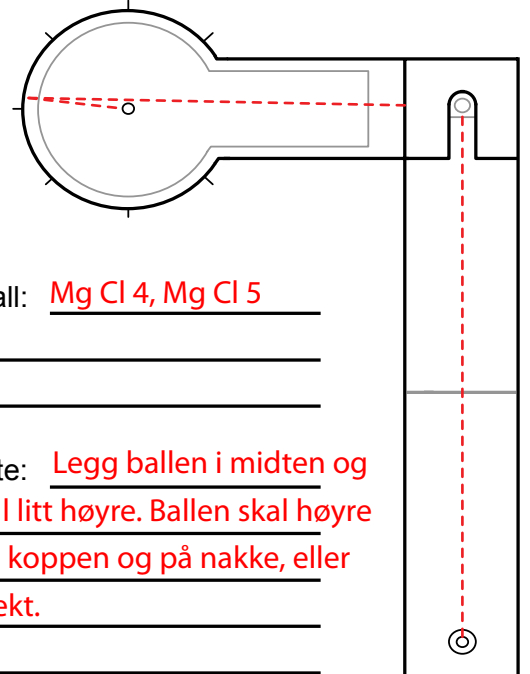

3 oyster

ball: BoF Karin Wiklund (hvit),
BoF Björklund (nakkesjans)

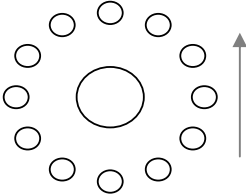
spot: 

note: _____

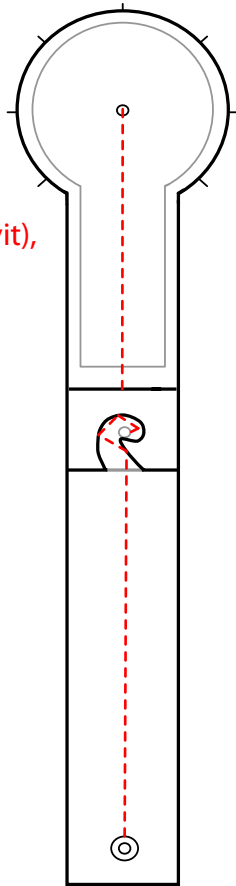

16 tube corner

ball: Klikker (gjennomsiktig)

note: _____

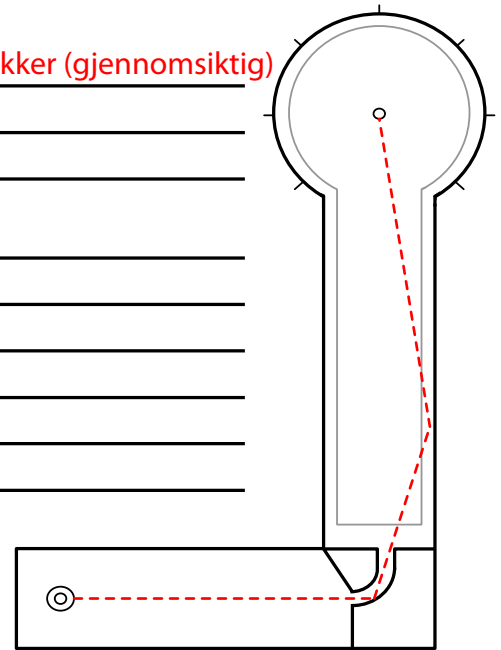

5 velodrome

ball: BoF Peter Matern, NIFO 5
DM Bel Ami (varm),
SV Switzerland 97

note: Legg ballen
halvveis mot venstre. Spill ballen
på klipset eller litt etter. Ballen
skal gå direkt i kopp, men
kan også gå på
nakke.

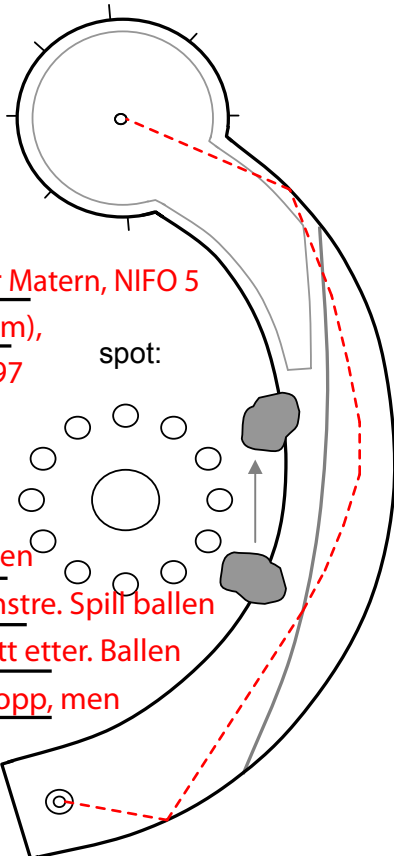

14 stones

ball: BoF Sara Marchiani,
BoF Ingrid Netzband,
SV Switzerland 2000 og 2001,
BoF Sandra Nordin

note: Spill to-vant-slag. Første
treff skal være ca 10-20 cm etter
3.klipset. Ballen skal gå
direkt, men kan også gå på
nakke.

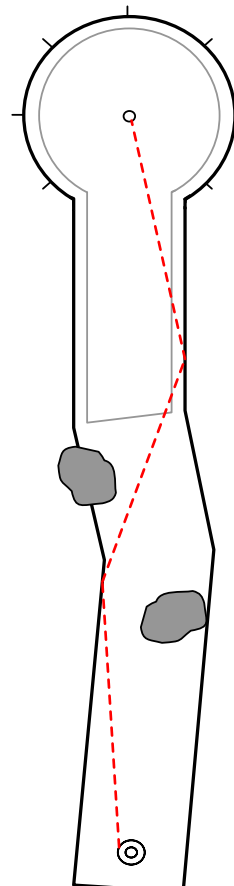

13 double velo

ball: Ravensburg Santro Pietro,
DM Ultra, SV Trofeo Nissan 2009

spot:

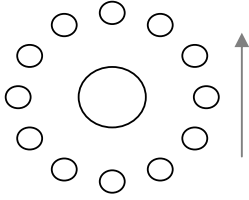

note: Legg ballen ca 5-10 cm
venstre. Ballen skal gå ca 40 cm
høyre om koppen og skal ha
3 vanttreff.

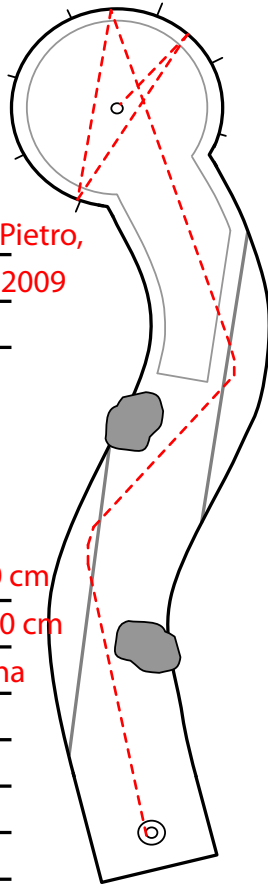

6 moat

ball: Ravensburg 250 og 251,
Mg Samtpfötchen 1 og 2

spot:

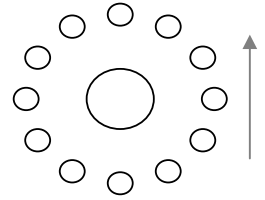

note: _____

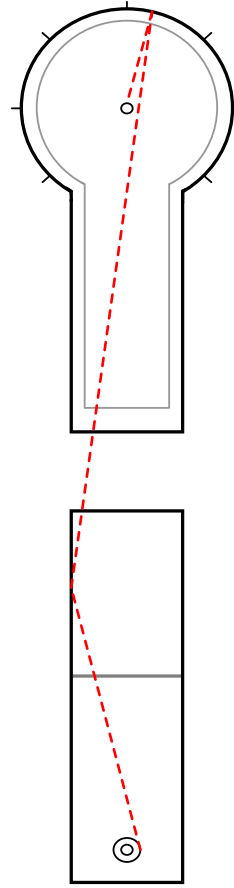

11 wall

ball: BoF Miroslav Stoparic

spot:

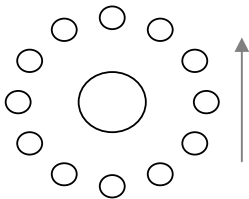

note: _____

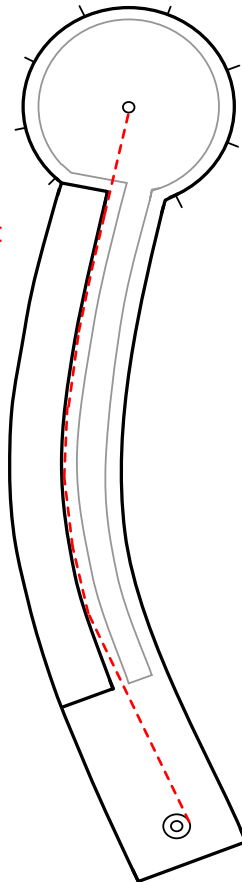

8 volcano

ball: BoF Karin Wiklund (hvit),
3D Zielpunkt

spot:

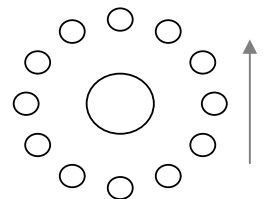

note: Død og myk ball. Banen
drar litt venstre. Legg ballen
venstre og spill høyre.

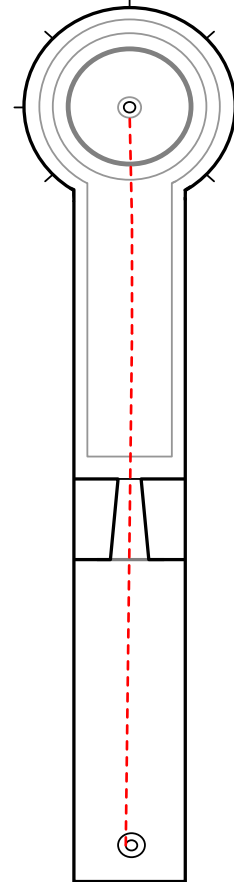

7 hammer cage

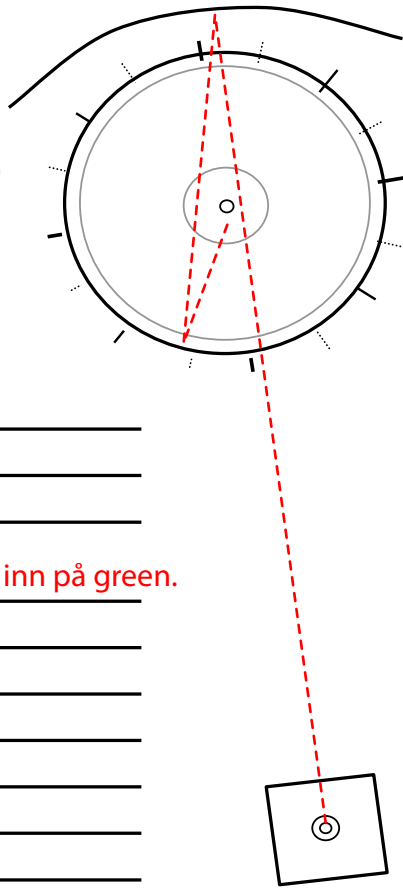

ball: Klikker

note: Slå ballen inn på green.

12 wide angle

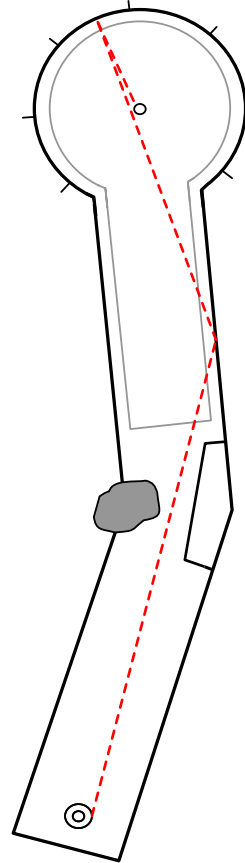

ball: 3D Balla-Balla IV, Mg Cl 4,
Mg Cl 5, Mg Maier Spezial,
Mg Maier Magnum 2

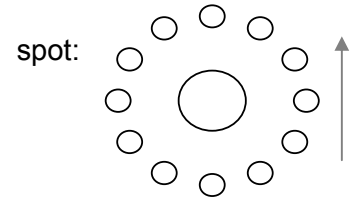

note: Legg ballen høyre og spill
uten hindertreff. Skal gå direkte
eller venstre om koppen.

ball: 3D 183

9 open corner

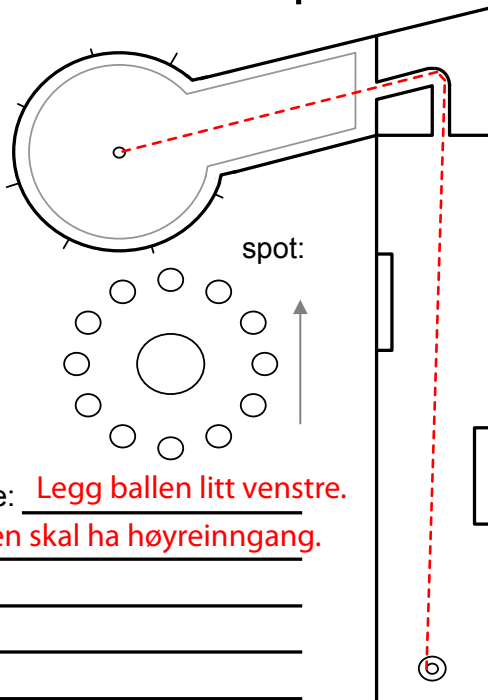

spot:

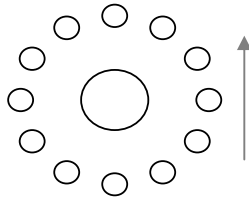

note: Legg ballen litt venstre.
Ballen skal ha høyreingang.

10 triple hill

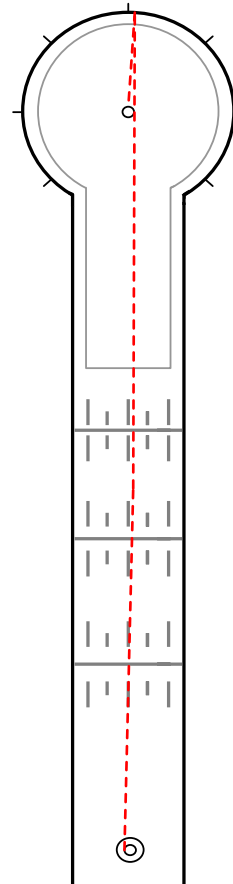

ball: SV Switzerland 97,
SV Switzerland 2000

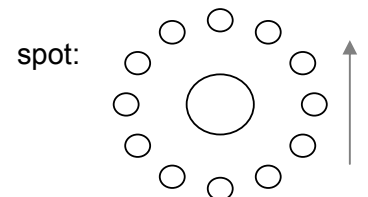

note: Legg ballen litt venstre
for midten og spill ballen litt
høyre. Den skal gå på nakke
helt inntil høyre om kopp eller
kopphugg.
